

FEATURES

- Magnetically shielded and molded type inductor, possible to decrease noise.
- Very high DC saturation current.
- Low core loss and very low DC resistance.
- Molded construction to be excellent identically performance and machnical strength.
- Suitable for wave soldering operations.

APPLICATIONS

- Suitable as circuit for digital amp, Motherboard and display card for computer DC/DC converter, etc.

特 征

- 磁屏蔽一体成型电感，可有效防止噪音；
- 超高饱和电流；
- 低损耗及超低直流电阻。
- 一体成型结构具优秀一致性和机械强度。
- 适合波峰焊接作业。

用 途

- 适用于数字功放电路，电脑主机板和显卡 DC/DC 转换等。

SHAPES AND DIMENSIONS (mm)

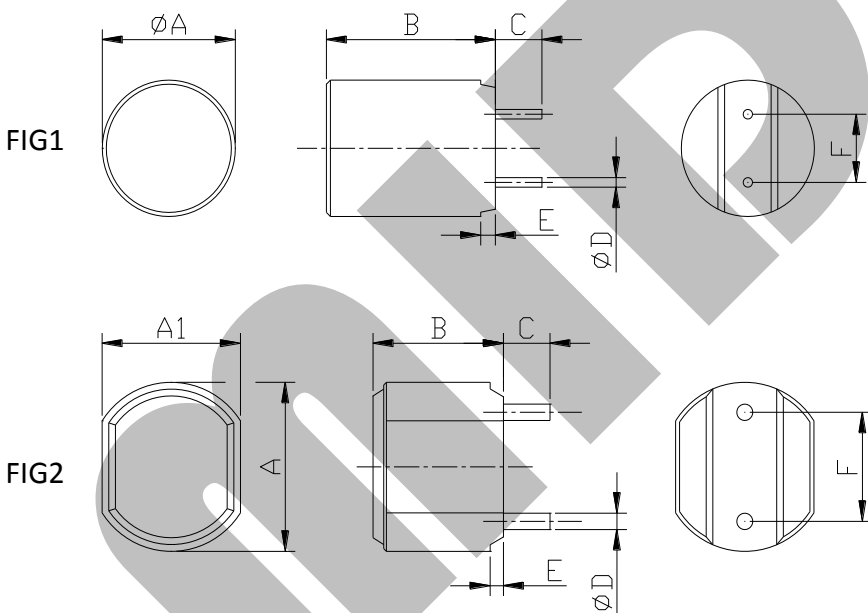

TYPE	A(±0.5)	A1(±0.5)	B(±0.5)	C(±0.5)	D(±0.5)	E(Ref.)	F(±0.5)	FIG
HPC1012-	10.0		12.7	3.5	By each P/N	1.0	5.0	1
HPC1215-	12.0		15.7	3.5	By each P/N	1.0	5.0	1
HPQ0807-	8.7	7.0	7.5	3.5	By each P/N	0.7	6.0	2
HPQ1210-	12.3	10.3	10.0	3.5	By each P/N	0.7	8.0	2
HPQ1315-	13.4	12.4	15.5	3.5	By each P/N	0.7	7.5	2
HPQ1512-	15.3	13.3	12.0	3.5	By each P/N	0.7	10.0	2

DIP MOLDING POWER INDUCTORS 一体成型插件功率电感

HPC/HPQ 系列

HPC1012-SERIES

P/N	L(uH)	DCR(mΩ)		D (mm)	Idc Temperature rise current	Isat Inductance decrease current
	Inductance	DC Resistance				
	± 20%	Max		± 0.2	Max	Max
100M	10.0	36		0.75	7.5	4.5
150M	15.0	76		0.75	8.0	3.5
220M	22.0	97		0.75	6.0	2.8
330M	33.0	115		0.75	4.0	2.3

HPQ0807-SERIES

P/N	L(uH)	DCR(mΩ)		D (mm)	Idc Temperature rise current	Isat Inductance decrease current
	Inductance	DC Resistance				
	± 20%	Typ	Max	± 0.2	Max	Max
R56M	0.56	2.20	2.50	0.8	18.0	32.0
1R0M	1.00	5.0	5.6	0.7	12.0	21.0
1R5M	1.50	6.6	7.5	0.6	10.5	18.0
2R2M	2.20	8.8	10.0	0.6	9.5	16.0
2R8M	2.70	10.4	11.8	0.6	8.5	15.0
3R3M	3.30	12.0	13.6	0.6	8.0	14.0
4R7M	4.70	15.0	17.0	0.6	7.5	12.0

HPQ1210-SERIES

P/N	L(uH)	DCR(mΩ)		D (mm)	Idc Temperature rise current	Isat Inductance decrease current
	Inductance	DC Resistance				
	± 20%	Typ	Max	± 0.2	Max	Max
R22M	0.22	0.50	0.60	1.4	38.0	56
R33M	0.33	0.70	0.80	1.4	33.0	48
R39M	0.39	0.70	0.80	1.4	33.0	45
R47M	0.47	0.85	1.00	1.5	30.0	40
R56M	0.56	0.85	1.00	1.5	30.0	40
R68M	0.68	0.85	1.00	1.5	30.0	40
R80M	0.80	0.85	1.25	1.4	26.0	36
1R0M	1.00	1.75	2.00	1.2	21.0	32
1R5M	1.50	3.00	3.50	1.0	16.0	30
2R2M	2.20	4.30	5.00	1.0	13.5	24
2R8M	2.70	5.60	6.40	0.9	12.5	20
3R3M	3.30	6.80	7.70	0.8	11.0	16
4R7M	4.70	8.80	10.00	0.8	10.0	15